

## 6. CUT SHEET

### FastPlank® System - Invisi-line with Reveals System

FastPlank® is a pressure-equalized aluminum rainscreen cladding system with integrated attachment. Concealed Clip-and-Slide technology and patented connectors accommodate thermal movement while maintaining flatness and preventing gapping or buckling.

#### FINISH OPTIONS

##### STOCK WOODGRAINS (4)



##### STOCK SOLID COLORS (4)



##### SPECIAL ORDER WOODGRAINS (20)

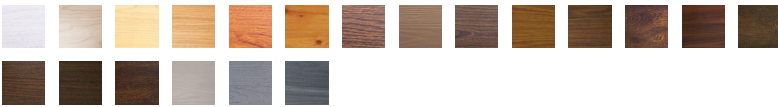

##### CUSTOM COLOR WITH COLORMATCH®



Stock Woodgrains and Solid Colors: ready to ship within 1–2 weeks.  
Special Order and Custom Colors: lead time varies depending on project specifics and needs.

#### FASTPLANK® SYSTEM – ALUMINUM TRIM SYSTEM PROFILES

##### PLANKS



##### TRIMS



##### ATTACHMENT & ACCESSORIES



#### INSTALLATION

RVT and DWG files are available on our website, [engagebp.com](http://engagebp.com)

Refer to individual profile cut sheets for detailed dimensions and tolerances.



For additional technical specifications, detailed profiles, and expanded system information, please scan the QR code.

PRODUCT	DOCUMENT	CATEGORY
Fastplank® System	Spec Sheet	Invisi-line with Reveal

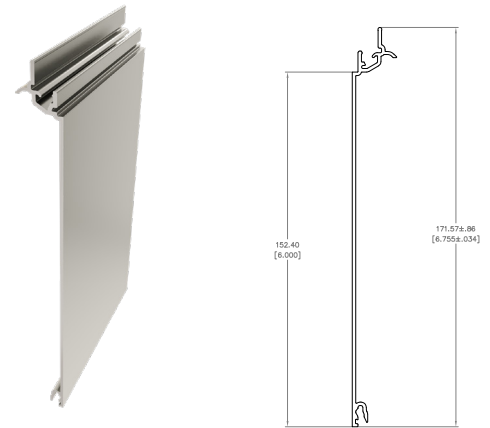

P96F - INVISI-LINE WITH REVEALS

#### TECHNICAL SPECIFICATIONS

##### PHYSICAL DATA

Material	6063-T6 Extruded Aluminum
Thickness	15 gauge (0.050 in / 1.27 mm nominal)
Finish	AAMA 2604 or AAMA 2605 compliant coating
Plank Connector	Integrated connector system for continuous runs up to 32 ft (9.75 m)
Attachment Method	Patented Clip & Slide™ Technology
Warranty	20-year Finish Warranty; 50-year Product Warranty
Length	16'-0" (4.88m)
Width	6" (152mm)
Weight (lbs/sqft)	-1.2 lbs/sq.ft. (5.9 kg/m²)
Substrate	Installed over approved sheathing per manufacturer instructions
Compatibility	10 pcs/box; 6 in planks: 6 pcs/box
Quantity	
Finish	AAMA 2604
Pressure Equalized Rainscreen	AAMA 508
Wind Resistance	ASTM E330 and E283
Water Resistance	ASTM E331
Impact Resistance	Florida Product Code: FLO093-3-1 Miami Dade, Florida, NOA No. 22-0615.01 Expiration Date: April 06, 2028
Impact Testing	TAS 201
Non-Combustible	WVU – California Department of Forestry & Fire Protection Office of the State Fire Marshal Listing No. 8140-2286:0500 Class A Non-Combustible by ASTM E136 and ASTM E84; CAN/ULC S144-18
Fire Rating	
Standards/ Codes Compliance	National Building Code of Canada Evaluation; 2024 International Building Code (IBC); 2024 International Residential Code (IRC); 2022 California Building Code (CBC); 2022 California Residential Code (CRC); ICC-ES Evaluation Report